

**Operating Manual
Vibratory Hammer
P-23/P-46**



Model : P-23, P-46
Manual no. : VB0040
Revision no. : -
Date of issue : 09-09-2008



www.Pileco.com

TABLE OF CONTENT

1 SAFETY INSTRUCTIONS.....	5
1.1 General.....	5
1.2 Safety precautions	5
1.3 Safety signs on the free hanging vibratory hammer	8
1.4 Safety instructions	9
1.5 Limits for operational conditions.....	10
1.5.1 Refusal	10
1.5.2 Rebound.....	10
1.5.3 Max. bearing temperatures	10
1.6 Incorporated safety precautions.....	10
2 DESCRIPTION OF THE EQUIPMENT	11
2.1 Description of the free hanging vibratory hammers	11
2.1.1 The main components the free hanging vibratory hammers.....	11
2.1.2 The vibration case	11
2.1.3 The suppressor housing	11
2.1.4 The clamp (option)	12
2.1.5 Rigging of vibrator.....	12
2.1.6 Installation	12
3 OPERATION.....	13
3.1 Clamping a pile.....	13
3.2 Starting/stopping vibration.....	13
3.3 Off-clamping from a pile.....	13
3.4 Emergency stop.....	14
3.5 Changing the frequency.....	14
3.6 Clamps	14
4 SPECIAL OPERATIONS.....	15
4.1 Operating instructions for Pileco-RF vibratory hammers.....	15
4.2 Operating at low temperatures.....	16
4.3 Operating under water (up to 10 m depth)	16
4.4 Operating in deep water (> 10m deep).....	17-18
5 MAINTENANCE	19
5.1 General.....	19
5.2 Daily maintenance	19
5.3 Weekly maintenace.....	20
5.4 Monthly maintenance.....	20
5.5 Yearly maintenance	20
5.6 Lubrication intervals (operating hours of the hammer)	21
5.7 Recommended liquids	22

5.8 Heavy driving conditions	22
5.9 Long term storage.....	22
5.10 Hydraulic oil	23
5.11 Lubrication of the vibration case under extreme circumstances	24
5.12 Maintenance of hydraulic circuit elements.....	24
5.13 Oil capacity	25
5.14 Bolt torque information.....	25-27
6 ORDERING OF PARTS.....	28
6.1 Procedure.....	28
6.2 Original equipment.....	28
6.3 Shipment	28
6.4 Shortages	28
6.5 Return of parts.....	28
6.6 Screws and bolts	28-29
6.7 Hoses	30
6.8 Fittings.....	31-32

Preface

This owner's manual has been written for the users of Pileco Inc. Vibratory hammers. The owner's manual explains how to use, service and inspect the hammer, with the intention to use the vibratory hammer safe and efficiently.

One copy of the present manual shall at any time be at the location where the hammer is in operation. When the instructions of this owner's manual are not strictly followed, accidents may happen, therefore, check if you have understood all instructions in this manual before you start using the vibratory hammer. For ordering of parts we refer to the parts manual of the relating vibratory hammer. For the operation of the power pack which may be attached to the vibratory hammer, we refer to the owner's manual of the relating manufacturer.

If operational or maintenance problems arise which are beyond the scope of this manual, please contact your dealer. They are prepared to assist you in order to make the best use of your equipment.

Please have the following at hand:

- Model
- Equipment serial number

1 SAFETY INSTRUCTIONS

1.1 General

Foundation equipment and especially pile driving hammers including vibratory hammers are designed to transfer extremely high energy from the pile driver/extractor to a pile and the soil beneath. The forces generated, either through impact or through vibration are so high that without proper maintenance and skillful operation the equipment has to be considered as self destructive and dangerous. Never exceed the maximum line pull of the hammer. The maximum line pull is mentioned on specification sheet of the hammer. Also, the system is operating under high hydraulic pressure. Therefore pay special attention to the safety instructions and the operation and maintenance sections in the present manual

1.2 Safety precautions

Pileco Inc. accepts no liability for any damage or physical injury caused by non-compliance with the safety instructions in this manual or by carelessness during the installation, use, adjustment or maintenance of the equipment. Regularly maintenance and skillful operation will not only lengthen the mechanical life, but is essential for the safety of the user.

! WARNING !

It is the responsibility of the user or operator to ensure that the local health and safety regulations are observed before and during the use of the equipment.

Operators

- Only trained personnel shall be permitted to operate the hammer.
- Temporary employees and trainees shall only be permitted to work with the equipment under the supervision and instruction of trained personnel.
- The operator of the hammer shall be familiar with the contents of the Owner's manual and shall follow the instructions accurately.

Always

- Watch a hammer in operation. Some parts might unexpectedly fail, fall down and injure people. Stop the operation **IMMEDIATELY** for a check if you expect that the above may happen.
- Pay attention to irregular or unusual noises and analysis where they originate from.
- Let the hammer cool down before you start maintenance or repairs on the hammer.
- Warn colleagues when you feel uncomfortable with the way the hammer is functioning.
- Stay away from moving or rotating parts.
- Remove all tools and electrical cords before starting the hammer.
- Use a safety chain on the sheet pile or casing

Never

- Run the hammer in horizontal position.
- Stay nearby a working vibratory hammer.
- Continue operation when it's known that one of the safety provisions is out of order or not working properly
- Continue operation when service inspection is due, or when a repair is necessary.

Tools

- Never use defective (maintenance) tools.
- Only use a tool for the purpose it was designed for.
Clothing and footwear
- When working with the equipment, do NOT wear rings, watches, jewelery or any loose clothing which could be caught in moving or rotating parts.
- Always wear protective goggles, a safety helmet, protective footwear and hearing protection specially suited for the work.
- Follow local health and safety regulations.

Water and moisture

- Do not allow water to enter the hydraulic system.
- NEVER direct a jet of water at electrical parts.
- Avoid internal condensation by rapid temperature changes
- Make sure all protective devices of the electric installation (if applicable) have been installed to guarantee adequate protection from moisture and water. Failure to do so can result in malfunction of safety circuits and cause harm to personnel and equipment components.

Technical specifications

- 1.** The permissible limits for operational conditions as mentioned in the present manual shall NOT be exceeded.

Safeguards

- 2.** Never change the settings of the valve(s) on the system. Only Pileco Inc. service engineers are allowed to adjust these valves.

Safety directions and warnings

- 3.** Any safety direction, warning or instruction fitted on the equipment shall NOT be removed, rendered illegible or covered. They shall be present and legible throughout the entire operating life of the equipment.

4. Illegible, damaged or covered safety directions, warnings or instructions shall immediately be replaced or repaired.

Service and maintenance

5. The service and maintenance activities shall only be carried out by qualified Pileco Inc. personnel or one of Pileco Inc. appointed and certified dealers in full compliance with all safety instructions and service intervals. Electrical system (if applicable)
6. Work on the electrical system or equipment shall only be carried out by skilled electricians. Hydraulic system
7. The hydraulic system is a high pressure high oil flow system. Work on the hydraulic equipment shall only be carried out by persons having special knowledge and experience in high pressure hydraulic systems.

Use according to purpose

8. In order to guarantee correct operation, the equipment should only be used in accordance with the purpose as described in this owner's manual.

Suspension

9. Always assure proper suspension of the vibratory hammer before operation. Make adjustments or repairs while the hammer is working.







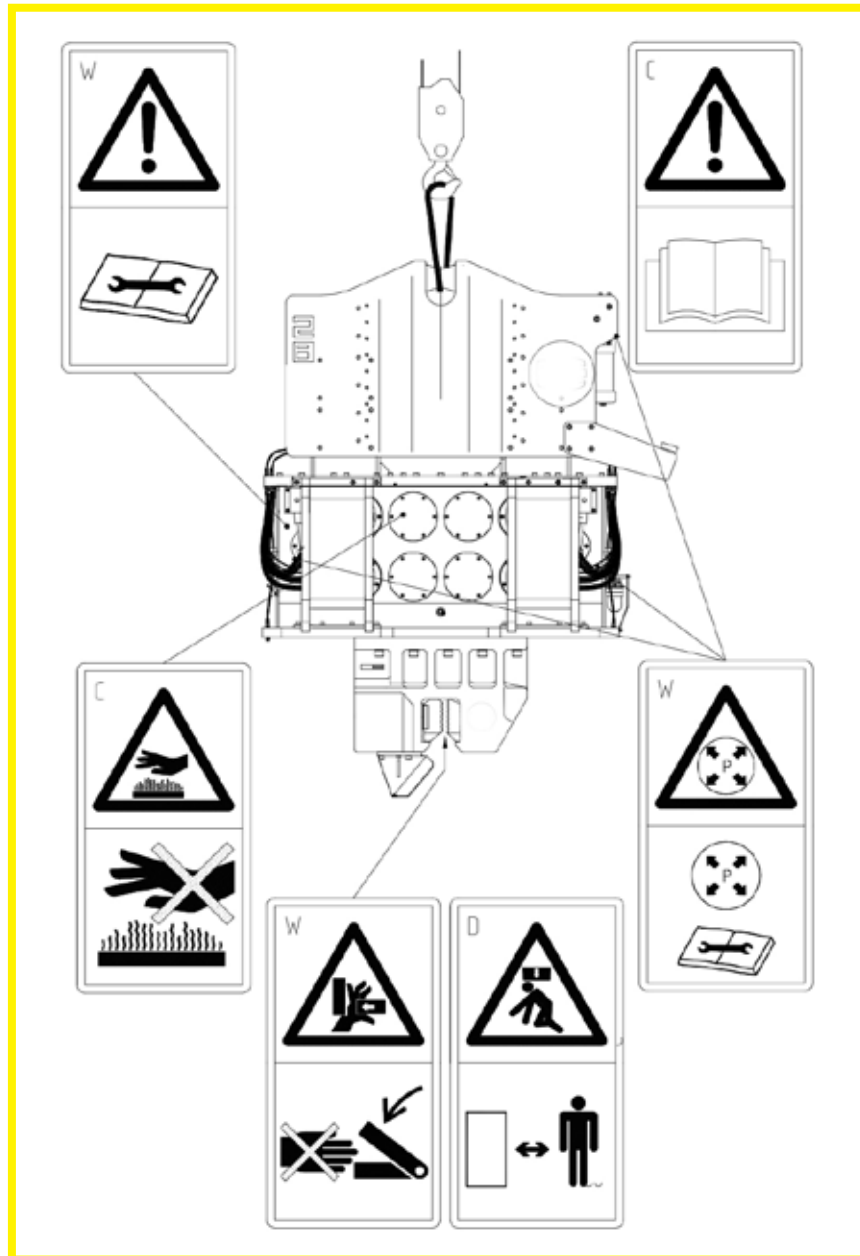





1.3 Safety Signs for free Hanging Vibratory Hammer and the Clamp

This part of the manual contains the description of the following Vibratory Hammers:

P-23 P-46



1.4 Safety instructions

HAZARD DESCRIPTION		HOW TO PREVENT
 	Safety sign	Read the operation manual
 	Make sure the machine is in good condition	Read the maintenance instructions in the owner's manual for proper service procedures
 	Surface can be hot	Do not touch, allow the surface to cool down.
 	Crushing of finger(s) or hand(s)	Never reach into the danger area as long as parts may fall down
 	Parts may fall down	Stay at a safe distance from the machine
 	Component is pressurized	Depressurise before maintenance

1.5 Limits for operational conditions

As with all machinery there is a limit for the operational conditions under which the machinery is expected to operate safe, long lasting and efficiently. For vibrating, Pileco Inc. defines these limit conditions for REFUSAL and REBOUND as shown below.

1.5.1 Refusal

Refusal under NORMAL conditions:

Less than 25 cm penetration per 5 min (10" per 5 min)

The penetration distance of 25 cm is absolute, no conversion is allowed to, for instance, 1 meter per 60 minutes.

1.5.2 Rebound

Rebound occurs when a large portion of the hammer's energy is transferred back into the pile as a result of force reflection at the pile tip. This may be due to the pile hitting a nearly impenetrable layer or obstruction. The rebound forces will be transferred back into the hammer and the hammerhead (suppressor head), as a result of which the head will start "jumping" relative to the vibratory case. In this situation driving should be stopped immediately and the hammer should be retracted.

1.5.3 Max. bearing temperatures

The maximum bearing temperature, as measured on the bearing covers (after some paint is removed), should not exceed 90 °C (194 °F).

IMPORTANT:

Pileco Inc. will not accept any warranty claims when the above conditions are not adhered to.

1.6 Incorporated safety precautions

The hammer has a number of built-in safety provisions which ensure that the risk for failures, human injuries and environmental pollution is reduced to a minimum.

- 1.** The hammer cannot be put in operation when the clamp is open.
- 2.** A pilot-operated check valve on the clamp ensures that the clamp pressure is maintained in case one of the clamp hoses fails.
- 3.** Individual pressure relief valves in pressure line, both clamp lines and leak oil line avoid over pressurizing these lines.
- 4.** Stopper blocks maintain a connection between vibration case and suppressor housing in case of elastomer failure.

All above mentioned safety precautions should be followed when the hammer is driven by a Pileco Inc. powerpack.

Precautions 2 & 4 should be followed by excavator mounted hammers.

Maintenance schedule

Before operation of the hammer, check the maintenance schedule. See chapter 5 Maintenance of the manual.

2 DESCRIPTION OF THE EQUIPMENT

2.1 Description of the free hanging Vibratory Hammers

This part of the manual contains the description of the following Vibratory Hammers

P-23

P-46

2.1.1 The main components the free hanging Vibratory Hammers

The hammer consists of 2 main components:

- 1.** Vibration case
- 2.** Suppressor housing

The hammer can be equipped with a hydraulic clamp.

- 3.** Hydraulic clamp (option)

2.1.2 The vibration case

The vibration case contains eccentric weights which rotate in a vertical plane to create vibration. The eccentric weights are driven by one, two or four hydraulic motor(s) mounted on the outside of the vibration case. The motor(s) and the eccentrics are gear connected to maintain proper synchronisation. The eccentric shafts are mounted in heavy-duty roller bearings. Lubrication is provided by a splash lubrication or by a forced lubrication system.

2.1.3 The suppressor housing

The extraction head contains rubber elements (elastomers) to isolate the vibrations from the vibration case to the crane or pile driving rig. The hammer is attached to the crane with a steel wire rope sling.

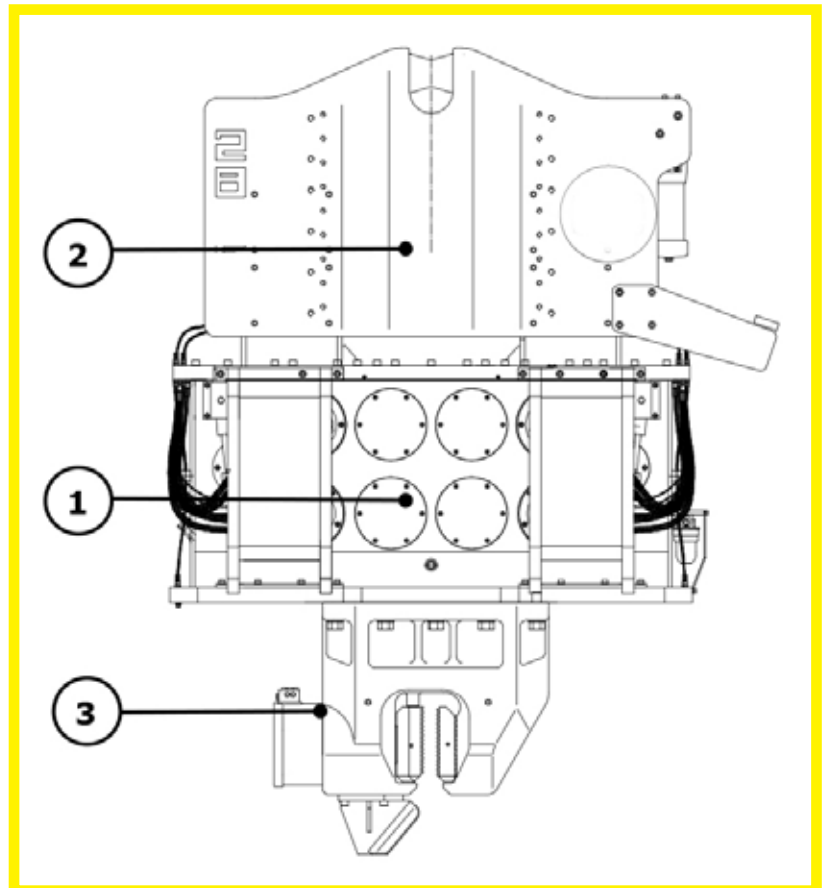

2.1.4 The clamp (option)

The hydraulic clamp contains two gripping jaws, one fixed and one moveable. An in the clamp body integrated cylinder operates the moveable jaw. The clamp cylinder is provided with a pilot operating check valve which keeps the clamp cylinder under pressure in case of hose damage.

2.1.5 Rigging of vibrator

A steel wire rope sling must be connected to the lifting pin of the suppressor housing. The required strength of this sling depends on the capacity of the crane and the work to be carried out. A safety factor of five is recommended. Several turns of a smaller diameter cable will usually last longer than one turn of a larger diameter cable. Daily check steel wire rope sling for damage. Immediately replace damaged steel wire rope sling. Refer to the table on the next page for general guidance on slings or grommets. Always check for local regulation(s) on steel wire rope sling.

General guidance for slings or grommets:

Max Linepull	Hammer type	grommet dia.	allowed single work load	allowed double work load
360kN	P23	54mm	31820 kg	47730 kg
400kN	P46	54mm	31820 kg	47730 kg

2.1.6 Installation

Please refer to the installation sheet of your hammer

3 OPERATION

In case of a pile driving rig, parts of the controls may be integrated in the pile driving rig and/or excavator. In such a case, please refer to the operating and maintenance manual of pile driving rig and/or excavator.

CAUTION

Make sure to have a clear view over the vibrator and the working area. Ensure that communication between the crane driver and other operators is always possible.

! WARNING !

Stay clear from the direct surrounding of the vibrator
Always allow the machine to warm-up by running at low RPM for some moments when starting.
The vibratory hammer may be operated from a cable pendant, a remote control or from the IQAN PLC of the power pack.

3.1 Clamping a pile

Position the vibratory hammer first over and then on the sheetpile. Turn the clamp switch to close. Don't start vibrating until the hydraulic clamp has reached maximum clamping pressure to permit vibration to begin. The clamp light on the power pack (if applicable) will light up when the hydraulic clamp has achieved adequate clamping pressure. The light will normally light up in a few seconds. Always use a safety chain or sling between the sheet pile or tube and the piling rig.

! DANGER !

Improper clamping may result in sheet pile and/or tubing releasing the clamp.

3.2 Starting/stopping vibration

Turn the vibration switch to start/forward or press the start button to start vibrating.

Turn the vibration switch to stop/reverse or press the stop button to stop vibrating.

CAUTION

Never use the emergency stop button for normal stops.

3.3 Off-clamping from a pile

Turn the clamp switch to open to release the hydraulic clamp so that the vibrator can be removed from the pile. Never open the clamp before the vibratory hammer has come to a complete stand still. Make sure, the pile or casing can not drop from the clamp when the clamp is opened.

3.4 Emergency stop

For an emergency stop, press the button on the power pack, crane, pile driving rig? or the remote control.

CAUTION

Before continuing operation reset the emergency stop button by turning it clockwise. Always reset the emergency stop button immediately after the hammer and power pack have been shut down completely.

3.5 Changing the frequency

In order to provide maximum flexibility in achieving optimum piling penetration and extraction rates, the frequency of the vibrator is adjustable. The frequency can be varied by changing engine speed. Engine speed is changed with the engine throttle or rpm +/- switch on the dashboard or on the remote control.

3.6 Clamps

Please refer to your clamp manual for operating instructions.

4 SPECIAL OPERATIONS

4.1 Operating instructions for Pileco-RF vibratory hammers

Pileco Resonance Free vibratory hammers allow starting up and stopping the vibratory hammer without vibration. This is achieved by shifting the upper row eccentrics with respect to the lower row of eccentrics. The total eccentric moment of the hammer can be varied from 0 -100%. For this reason there is/are one or two actuator(s) on the hammer.

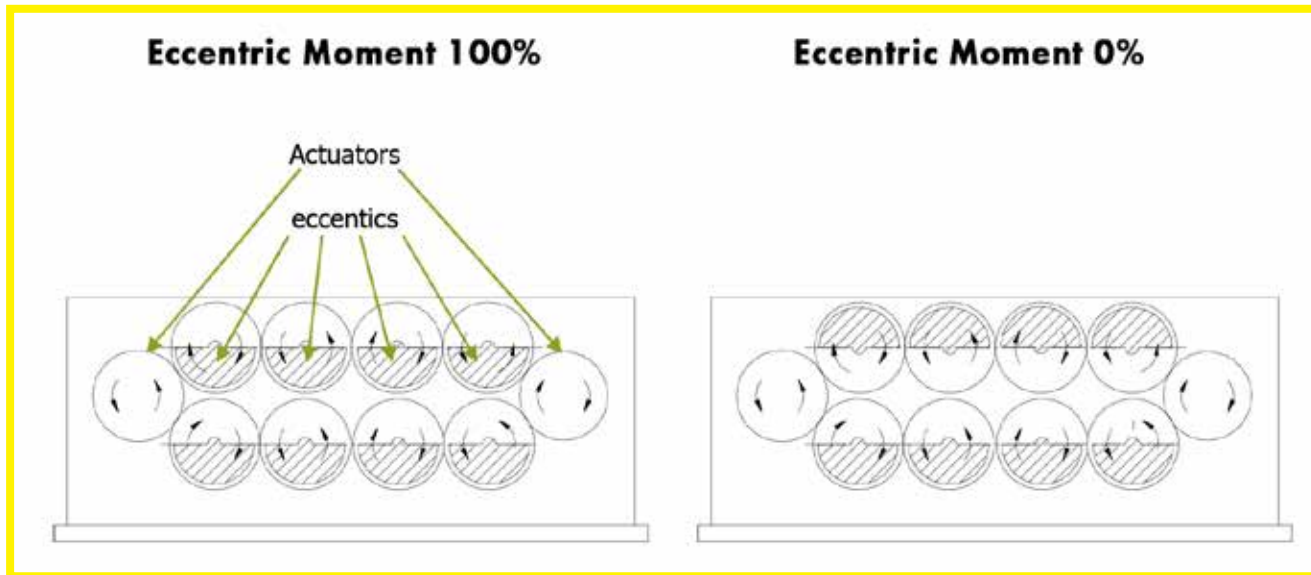

Proceed as follows:

- Start the diesel engine and warm-up as described in the operating manual of the power pack.
- Increase the diesel engine rpm.
- Hold the ecc **mom switch** on the remote control in [-] position until pressure has reached 190 bar. This will take a few seconds.
- Start the hammer.
- Wait until the eccentrics rotate at full speed.
- Hold the ecc **mom switch** on the remote control in [+] position until the required amplitude or maximum vibration level is reached.
- To stop the hammer proceed in reverse order.

4.2 Operating at low temperatures

When using the hammer at low ambient temperatures (below 10°C), please make sure that you carry out the following instructions

- When starting the hammer **never** run the hammer at maximum rpm immediately. Allow the machine and the oils to warm-up.
- Make sure that the bearings get enough oil by taking off one of the bearing covers (with forced lubrication hammers at the position furthest away from the oil input location.)
- The lubrication oil may be changed for a lower viscosity oil. However, care should be taken to have the correct oil viscosity at operational temperature. In case of doubt, measure hydraulic oil and vibration case lubrication oil temperatures and contact Pileco with these values.
- One should check the oil viscosity also at higher temperatures as the hammer warms up rapidly at full speed.

4.3 Operating under water (up to 10 m depth)

It is recommended to contact Pileco for under water operation. Pay attention to the following when operating under water with the vibratory hammer:

- Check the seals and gaskets (O-rings, gasket between vibration case and vibration case adapter).
- Check all bolt connections.
- Remove the vibration case breather and replace it by a plug.
- Check for possible leakage by increasing the pressure in the vibration case to approx. 0.2 bars.
- Check all hydraulic hoses for leakage.
- Check the oil level in the vibration case (case level)
- Connect the vibration case to a compressor and increase the pressure in the vibration case to 0.5 bars over pressure.
- Increase the air pressure to 1.0 bar over-pressure when the hammer is at 5 m below the water line. In this way there is a constant excess pressure of min. 0.2 bars and max. 0.5 bars present.
- During under water operation regularly check the oil level. If the oil becomes white/grey check immediately for leakage and replace the oil.
- Check the lubrication oil after completing the work under water and change the oil when required

CAUTION

Watch carefully that the hammer is not “hot” when lowered or driving through the water surface. This may cause a thermo-shock and damage the vibration case and its contents.

CAUTION

Excess pressure of more than 0.5 bar may damage the transmission case. In case of water depths of over 10m, always use the air regulation system for under water operation.

CAUTION

Check lubrication oil regularly during and in any case after completion on water content. Water may also enter the case as condensate from non-dried compressed air.

4.4 Operating in deep water (> 10m deep)

Contact Pileco for preparation for deep water operation. An air regulating system must be installed for deep water operation.

Air regulation system

Before operating, read and check the vibratory hammer according to chapter 5 of this manual.

Connect the air regulating system to an air compressor with an air buffer. The air pressure you need under water is 1/10 of the depth in meters. For example, 200 meters under water = $200 \times 1/10 + 1.1 \text{ bar}^* = 21.1 \text{ bar}$

! WARNING !

By lowering and retrieving the hammer be aware of the maximum speed of 15 mtr/min.

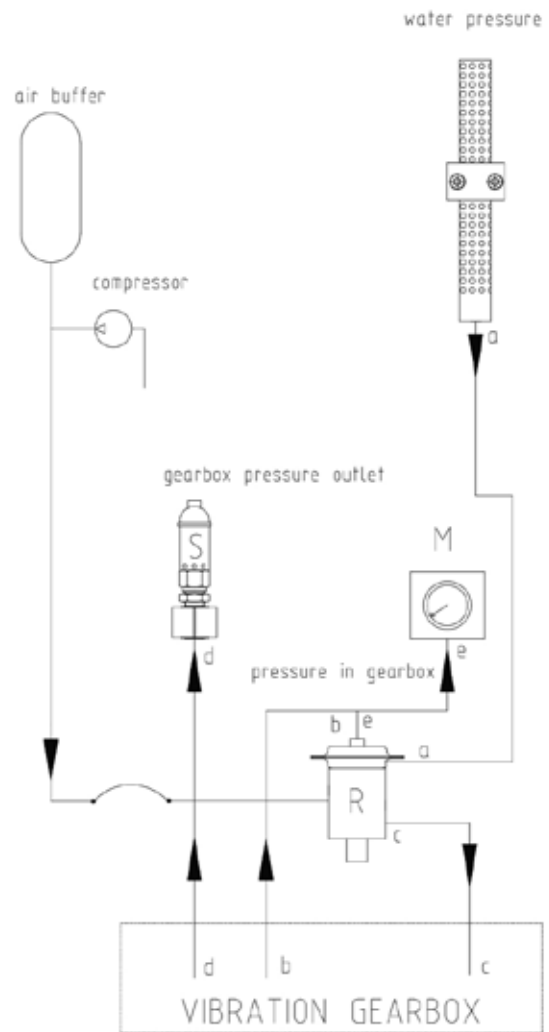
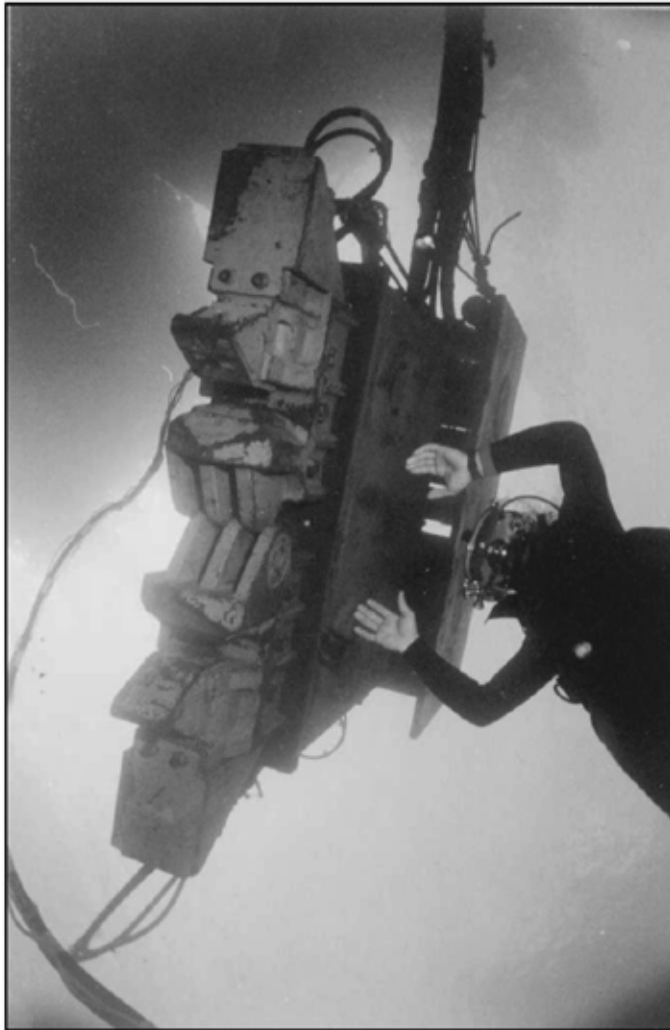

Testing the air regulating system

- Disconnect the hose (b) from air valve R.
- Screw a plug in the hose connector .
- Start the compressor. At 1.1 bar over-pressure the safety valve S will be opened (you can hear the valve breath out).The 1.1 bar overpressure is needed to avoid leaking seawater into the vibration gearbox.

Maintenance

After operating under water check the oil of the vibration gearbox. (refer to chapter 5) Check the membrane of the air regulating valve every 6 months by removing the screws of the cover. When it's damaged, replace it.

5 MAINTENANCE

! D A N G E R !

All maintenance work is strictly reserved to qualified and authorized personnel. Except for the visual inspections, all maintenance work must be carried out with the diesel engine stopped. Make sure that the main power switch is in **OFF** position. Install a **DO NOT OPERATE** or similar warning label to the main power switch.

5.1 General

Preventive maintenance includes normal servicing in order to keep the vibratory hammer in operation condition and prevents unnecessary breakdowns. The preventive maintenance consists of periodic inspection and exchange of the liquids, filters and moving parts of the unit.

Lubrication is essential for the system, determining to a great extent the useful life of the vibratory hammer. Therefore it is important that the instructions regarding types of oils and exchange intervals are closely adhered to.

- Prevent dirt from entering lubricants and the system.
- Thoroughly clean all lubrication fittings, caps, filter plugs and level plugs and their surrounding surfaces before servicing.

5.2 Daily maintenance

The daily instructions apply to routine or daily starting of a vibratory hammer.

- Each day -or at the beginning of each shift- check the entire vibratory hammer before start-up, after start-up and during operation.

Before start-up, proceed as follows:

- Inspect all bolts, nuts and screws. If necessary tighten.
- Check the oil level in the vibration case and if required fill to the proper level. The oil level should be between the middle and top of the sight glass. Change oil if it is milky or black
- Visually check all hoses for signs of damage or cuts that may cause hose failure during operation. Be sure all connections are tight, especially the quick-disconnect couplers.
- When the first steel layer of the hose is damaged, it should be replaced
- Visually inspect all suppressor elastomers on cracks and loose bolts
- Visually inspect for cracks in metal parts.

After start-up:

- Check all hydraulic hoses for leaks. Make sure they hang freely with no kinks.
- Check the hydraulic manifold and fittings for leaks.

During operation:

- Be alert on rattling noises. These may indicate that one or more bolts have come loose. Check all bolts immediately and re-tighten them.
- Rattling noises may also indicate gear case failures
- Handle all hoses with care and pay attention that no sharp curves or bends occur.

5.3 Weekly maintenance

- Tighten all bolts on the hammer and the hydraulic clamp. Always use a torch wrench. To obtain the listed torque, a steady pull should be exerted to the handle until the desired torque is reached.
- Check the air breather, located on the side of the hammer. If necessary, clean the breather with diesel fuel.

5.4 Monthly maintenance

- Check the proper functioning of the forced lubrication pump by removing a plug or a hose on the pressure side of the pump.
- Check on the hour counter of the engine if the vibratory hammer is due for inspection or maintenance.
- Check the functioning of the pump.

5.5 Yearly maintenance

- Have the hydraulic fluid analyzed by a local hydraulic service center. Replace fluid if required. Refer to paragraph 5.7 Recommended liquids.
- Replace the forced lubrication pump on the vibration case.
- Have the hydraulic system inspected by Pileco (authorized) service personnel.

CAUTION

Any contamination of the hydraulic fluid will drastically shorten the life of the high-pressure hydraulic system.

5.6 Lubrication intervals (operating hours of the hammer)

INSPECTION INTERVALS BASED ON OPERATING HOURS VIBRATORY HAMMER						
Description		Normal driving conditions		Heavy driving conditions		Min.
		First	Interval	First	Interval	
Hammer	Oil level	Check level				daily
	Lubrication oil vibration case	25	100	10	50	Yearly
	Main hydraulic filter (optional)	25	100	10	50	Yearly
Cooler unit	Filter forced lubrication system	25	100	10	50	Yearly
	Lubrication pump	Monthly		Every 2 weeks		Yearly
Bearings	(Optional)	500		250		Yearly
Actuator		500		250		Yearly
Elastomers		Check for hair cracks				Daily
Hoses		Check for damaged steel wire				Daily
Clamp		Check for leaks				Daily
Bolts, nuts and screws		Check torque				Daily

CHANGE INTERVALS BASED ON OPERATING HOURS VIBRATORY HAMMER						
Description		Normal driving conditions		Heavy driving conditions		Min
		First	Interval	First	Interval	
Hammer	Lubrication oil vibration case	50	200	25	200	Yearly
	Main hydraulic filter (optional)	50	200	25	200	Yearly
	Hydro engines				200	Every 5 years
Cooler unit	Filter forced lubrication system	50	200	25	200	Yearly
	Lubrication pump		500		500	Yearly
Bearings	(Optional)	1500		1000		Every 3 years
Actuator		1500		1000		Every 3 years
Elastomers		Exchange when small haircracks are visible				Every 5 years
Hoses		Exchange when first steel layer is damaged				Every 2 years

- When operating in an environmental air with high salt or moisture content, the service intervals need not to be changed. However, the unit shall be thoroughly inspected weekly to determine what additional servicing, if any, might be required.
- During stand-by or inactive periods, the service intervals may be extended twice from those specified. 5.7

5.7 Recommended liquids

TEMPERATURES	NORMAL AMBIENT	HIGH AMBIENT	LOW AMBIENT	EXTREME LOW AMBIENT
	-10°C < T < 55°C	T > 55°C	-20°C < T < 20°C	-35°C < T < 20°C
VIBRATION CASE FORCED LUB	Total Carter SH 220	Total Carter SH 220	Total Carter SH 220	Total Carter SH 220
VIBRATION CASE SPLASH LUB	Total Carter SH 460	Total Carter SH 460	Total Carter SH 460	Total Carter SH 460
HYDRAULIC OIL	Total EQUIVIS ZS 46 Alt. Total EQUIVIS XV 46	Total EQUIVIS ZS 68	Total EQUIVIS ZS 32	Total EQUIVIS XV 32
BIO OIL	Total BIOHYDRAN TMP 46	Total BIOHYDRAN SE 46	not recommended	not recommended
ENGINE OIL	Total Rubia TIR 7400 15W40			
ENGINE COOLANT	50% Total GLYCOLFREEZE + 50% water + additive			

5.8 Heavy driving conditions

The following conditions have to be considered heavy driving conditions

- When the average temperature is above +30 °C or below -20 °C
- When operating in excess of 8 hours per day
- Leader guided machines are considered heavy driving conditions.

5.9 Long term storage

Should the hammer not be used for any extended period of time (approximately 2 – 3 months), the gear case lubrication oil should be removed and the complete gear case be filled by any type of oil. The hammer should preferably be stored vertical, otherwise with the hydraulic motors facing upwards. When laid down the hammer head should be supported slightly higher than the clamp to ensure that the bearings facing upwards are filled with oil as well and are not trapped in an air gap. If it is not possible to fill up the gear case with oil, the hammer should be run at least every 3 to 4 weeks.

5.10 Hydraulic oil

New power units are shipped with Total Equivis ZS 46 hydraulic oil, unless otherwise specified by the client. Check label in power pack for actual oil type. When replacing fluid other than this, use a fluid with the following specifications:

Viscosity INDEX	150
Viscosity (mm ² /s)	46,6 @ 40°C 31,3 @ 50°C 8,2 @ 100°C
ISO.VG	46
DIN 51524	HLP 25

When operating in arctic conditions, it is recommended to use an immersion heater to preheat the oil prior to starting. It may also be necessary in extreme cold or hot climates to use a different viscosity oil which is better adapted to adverse conditions

- Contact the nearest oil supply representative for suggested procedures

Biodegradable hydraulic oil

It is allowed to use biodegradable oil in combination with Pileco equipment, but only if the biodegradable oil is an ester-type oil with the same specifications as the mineral oil used by Pileco. Operating the hammer with other types of biodegradable oil is not allowed. Should you have any doubt, please contact Pileco before using the oil.

Lubrication oil vibratory gear case

The fluid level is easily read through the side-glass located at the lower center of the long side of the vibratory case (motor side). Under normal gear case temperatures the level of the lubrication oil shall be at mid-level of the side glass. Lubrication gear oil may be added when necessary through the special filling plug or through the vibration case top plate, above the motor recess. The oil may be drained by removing the plug at the motor end of the base plate.

The most preferred lubrication oil is a synthetic lubricant, since synthetics were designed for applications where service conditions are more severe due to high operating temperatures. Moreover they have good oxidation stability. Synthetics also provide considerably longer service life than natural, petroleum-based lubricants consequently resulting in less maintenance hours spent on the mechanic service of the unit. The vibration case lubricant (synthetic).

VISCOSITY INDEX	TOTAL 150	TOTAL 155
Viscosity (mm ² /s)	218,0 @ 40°C 137,6 @ 50°C 25,9 @ 100°C	430,0 @ 40°C 264,5 @ 50°C 44,5 @ 100°C
ISO.VG	220	460

The vibration case lubricant installed at the factory is Total Carter SH 220 for systems with forced lubrication and Total Carter SH 460 for systems with splash lubrication. When replacing the lubricant, a gear oil with the following specifications must be used:

5.11 Lubrication of the vibration case under extreme circumstances

Extreme circumstances are e.g.:

- Outside temperature over 55 °C.
- Soil compaction , semi-continuous operations like installation of drains, installation of diaphragm walls, etc.
- Long driving times at high operating pressure.
- Rebound

In these cases, the temperature in the vibration case may rise to 60 °C - 70 °C. Please contact Pileco with actual vibration case temperature for recommendations on lubrication oil and special instructions.

5.12 Maintenance of hydraulic circuit elements

NOTE:

Check all lines, hoses and connections regularly for leaks and obvious damage. Repair damage immediately; splashed oil may cause injuries, fire and contaminations.

CAUTION

Any contamination will drastically shorten the life of the high-pressure system. Therefore, the hydraulic oil should be kept clean and no dirt should enter when (re-)filling.

5.13 Oil capacity

OIL CAPACITIES PER MODEL	
Model	Quantity
P23	± 10
P46	± 70

NOTE:

When an oil cooler for forced lubrication is used: 25l extra for cooling system.

5.14 Bolt torque information

The following torque specifications apply to the bolts from the component assemblies listed. Whenever any of these bolts are replaced, the given torque specifications shall be adhered to. Refer to the tables next page.

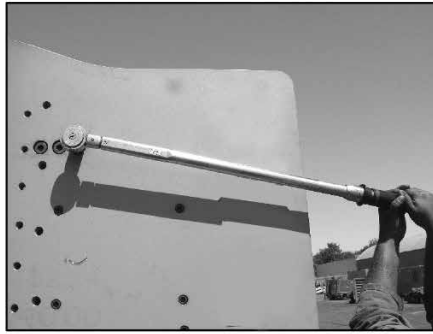

Tightening Moments

Tightening moment and force for UNC bolts with coarse pitch

Diameter [mm]	Pitch [mm]	Tightening force [KN]			Tightening moments [Nm]		
		Class	Class	Class	Class	Class	Class
1/4"	4.2	8.8	10.9	12.9	8.8	10.9	12.9
5/16"	3.7	8.0	11.3	13.5	10	14	17
3/8"	3.4	13.2	18.5	22.3	20	28	33
7/16"	3.3	20.8	29.2	35.1	38	53	64
1/2"	3.1	28.5	40.1	48.1	60	85	102
5/8"	2.9	38.0	53.4	64.1	91	129	154
3/4"	2.7	60.5	85.0	102	178	250	300
7/8"	2.5	89.4	126	151	309	435	522
1"	2.5	129	182	218	514	723	867
1 1/4"	2.3	169	238	286	774	1088	1306
1 1/2"	2.2	271	381	457	1532	2154	2585
		392	552	662	2659	3740	4488

Tightening moment and force for UNC bolts with fine pitch

Diameter [mm]	Pitch [mm]	Tightening force [KN]		Diameter	Tightening moments [Nm]		
		Class	Class		Pitch	Class	Class
1 1/8"x12	2.12	8.8	10.9	12.9	8.8	10.9	12.9
1 1/4"x12	2.12	247.4	347.9	417.4	1229	1728	2073
		310.3	436.3	523.6	1704	2397	2876

Tightening moment and force for metric bolts with coarse pitch

Diameter [mm]	Pitch [mm]	Tightening force [KN]		Diameter	Tightening moments [Nm]		
		Class	Class		Pitch	Class	Class
M6	1.0	8.8	10.9	12.9	8.8	10.9	12.9
M8	1.3	8.2	11.6	13.9	10	14	16
M10	1.5	15.0	21.1	25.3	23	33	39
M12	1.8	23.8	33.4	40.1	46	64	77
M14	2.0	34.5	48.5	58.2	78	110	132
M16	2.0	47.3	66.5	79.8	125	176	211
M18	2.5	66.2	93.1	112	198	278	333
M20	2.5	81.3	114	137	275	387	465
M22	2.5	103	145	174	386	542	651
M24	3.0	128	180	216	522	734	881
M27	3.0	149	209	251	667	937	1125
M30	3.5	194	273	327	966	1358	1630
M33	3.5	237	333	400	1318	1854	2225
M36	4.0	293	431	517	1788	2628	3154
M39	4.0	345	507	609	2297	3377	4053
M42	4.5	412	606	727	2950	4338	5205
M48	5.0	473	696	835	3669	5394	6473
M56	5.5	623	915	1098	5504	8091	9709
M64	6.0	857	1261	1513	8842	12999	15599
		1130	1662	1994	13199	19405	23286

Tightening moment and force for metric bolts with fine pitch

Diameter [mm]	Pitch [mm]	Tightening force [KN]		Diameter	Tightening moments [Nm]		
		Class	Class		Pitch	Class	Class
M16x1.5	1.5	8.8	10.9	12.9	8.8	10.9	12.9
M20x1.5	1.5	74.9	105	126	219	309	370
M24x2	2.0	122	171	205	440	619	743
M30x2	2.0	172	242	291	752	1057	1268
M36x3	3.0	278	391	470	1503	2113	2535
		387	545	654	2536	3567	4280

6 ORDERING OF PARTS

6.1 Procedure

When ordering parts, be sure to include the model and serial number of the unit or component. Confirm all telephone and/or e-mail orders immediately to avoid duplicating shipment.

6.2 Original equipment

Where serial numbers are given, these numbers only apply to equipment and components originally furnished with the unit. Where equipment has been changed or added to, these numbers may not necessarily apply.

6.3 Shipment

State to whom shipment is to be made and method of shipment desired, otherwise our own judgment will be made.

6.4 Shortages

Claims for shortages or errors shall be made immediately on receipt of parts. No responsibility will be assumed for delay, damage or loss of material while in transit. Broken, damaged or loss of material shall be refused or a full description made of damage or loss to the carrier agent on the freight or express bill

6.5 Return of parts

If for any reason you desire to return parts to the factory or to any distributor from whom these parts were obtained, first secure permission to return the parts. Shipping instructions will be given along with this permission

6.6 Screws and bolts

Almost all connections on the unit are made with socket-head cap (Allen) screws. These high-strength screws are available at most industrial supply houses. Screws and bolts are designated in the **PARTS LIST** in abbreviated form. The information, in parenthesis, immediately following the bolt or screw designation shows the size as follows:

½ - 13 x 1 ½

½" Diameter
13 Threads Per Inch
1 ½" Length



NOTE:

Some screws or bolts require a specific torque when replacing. For identification of these bolts and a more thorough understanding of torque, refer to section 5.14.

ABBREVIATIONS USED

BHCS	Button Head Cap Screw	HSSS	Hex. Socket Set Screw
FHCS	Flat Head Cap Screw	PHMS	Philips Head Machine Screw
FLCS	FLanged head Cap Screw	RHMS	Round Head Machine Screw
HC	High Collar	SHCS	Socket Head Cap Screw
HHCS	Hex. Head Cap Screw	SHPP	Socket Head Pipe Plug
HHPP	Hex. Head Pipe Plug	SHSS	Socket Head Shaller Screw

6.7 Hoses

EXAMPLE OF HOSE DESIGNATION

	A	B	C	D	E	F	G	H	I	J
HOSE	125	R01	F	9	24	P	0	20	LO395	S









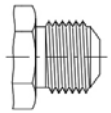

EXPLANATION OF HOSE CODES

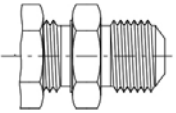
<p>A HOSE I.D. (3 digits) (125 = 1/14") (050 = 1/2"), etc. In inches; 2 place decimal</p> <p>C FIRST END – TYPE OF FITTING (1 digit) (F = 3000 PSI Flange) (P = NPT-male) (H = 6000 PSI Flange) (M = JIC-male) (J = JIC-female swivel), etc.</p> <p>E FIRST END – SIZE(2 digits) (In 1/16th)</p> <p>G SECOND END – BEND ANGLE (1 digit) (See codes for first end)</p> <p>I LENGTH In inches; 1 place decimal (0395 = 39 1/2") (1240 = 124"), etc.</p>	<p>B SAE or MANUFACTURER RATING (3 digits) (PT4 = Power Track) (R01 = SAE Rating 100R1), etc.</p> <p>D FIRST END – BEND ANGLE (1 digit) (0 = None) (3 = 30°) (9 = 90°),etc.</p> <p>F SECOND END – TYPE OF FITTING (1 digit) (See codes for first end)</p> <p>H SECOND END – SIZE (2 digits) (in 1/16th)</p> <p>J SPECIAL CODES (0 = None) (S = Spring Guard) (L = S.S.Braid) (D = Offset)</p>
--	--

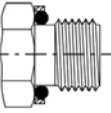
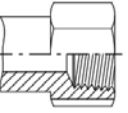
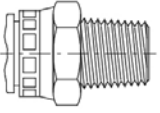
6.8 Fittings

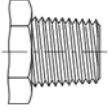
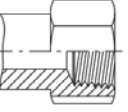
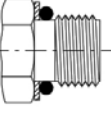
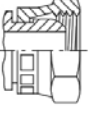
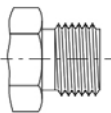
EXAMPLE OF FITTING DESIGNATION													
	A	B	C	D	E	F	G	H	I	J	K	L	M
FITT	2	L	16	M	12	J	0	0	00L	0	0	0	1

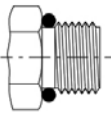
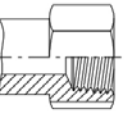
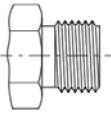
EXPLANATION OF FITTING CODES	
<p>A SELECTOR INDEX 2: inch fittings 9: metric fittings</p> <p>C FIRST END SIZE In sixteenth of an inch (index 2) In millimetres (index 9) Exceptions: 90 = 10" 94 = 14" 98 = 8" 92 = 12" 96 = 6" 99 = none code size See general specification sheet for sequence of order.</p> <p>E SECOND END SIZE If applicable. See first end size.</p> <p>G THIRD END SIZE If applicable. See first end size.</p> <p>FOURTH END SIZE (crosses only) See first end fitting size or end style.</p> <p>I LENGTH CODE pipe nipples (long) only (in decimal inches for index 2) 050 = 5.0 inches 105 = 10.5 inches In millimetres for index 9 120 = 12.0 inches 084 = 8.4 inches</p> <p>LENGTH CODE (elbows / nipples) 00L – long (elbow) 00C – close (nipple) 00x – extra long (elbow) 00S – short (nipple)</p> <p>K PRESSURE RATING 0: not applicable 1: 125 lb 3: standard weight (40) 4: extra heavy (80)</p> <p>M MATERIAL 1: carbon steel 2: brass 3: cast brass 4: stainless steel 5: A.A.R. mal. Iron 6: maleable iron 7: cast iron 8: forged steel 9: aluminium</p>	<p>B CONFIGURATION OR SHADE OF FITTING S: Straight fitting C: Cap L: 90° elbow P: Plus V: 45° elbow U: Union, pipe T: Tee X: Cross (fourth end fitting required).</p> <p>D FIRST END FITTING STYLE See fitting style selector chart.</p> <p>F SECOND END FITTING STYLE If applicable. See first end fitting style.</p> <p>H THIRD END FITTING STYLE If applicable. See first end fitting style.</p> <p>FOURTH END FITTING STYLE (crosses only) See first end fitting size or end style.</p> <p>J INSTALLATION AID OR STYLE OF HEAD 0: not applicable. H: regular hex. W: wide or large hex. Q: square head (ext.) R: square head (int) S: hex. head (int. socket) T: hex. head (ext.)</p> <p>L SPECIAL NOTATIONS 0: none A: tapped hole in fitting B: orifice F: special fab., non-stock item. G: galvanized M: magnetic</p>

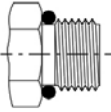
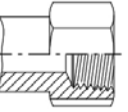
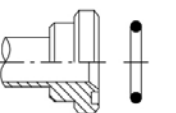
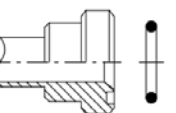
M		JIC MALE 37° FLARE	J		JIC FEMALE SWIVEL 37° FLARE
B		JIC MALE BULKHEAD 37° FLARE	T		BSP FEMALE SWIVEL
S		BSP MALE	G		BSP FEMALE
D		NPTF MALE SWIVEL	N		NPTF FEMALE SWIVEL
P		NPTF MALE	Q		NPTF FEMALE
R		UNF MALE (SAE)	K		UNF FEMALE SWIVEL (SAE)
A		METRISCH MALE (L)	V		METRISCH FEMALE SWIVEL (L)
U		METRISCH MALE (O-RING) (L)	W		METRISCH FEMALE (L)
C		METRISCH MALE (S)	Y		METRISCH FEMALE SWIVEL (S)
X		METRISCH MALE (O-RING) (S)	Z		METRISCH FEMALE (S)
F		FLANGE COUPLING (standaard)	H		FLANGE COUPLING (high pressure)